

DEVILBISS
AUTOMOTIVE REFINISHING



DV1
CLEARCOAT

REFLECT PERFECTION



IN THE CLEAR

EXPERIENCE THE NEXT GENERATION OF APPLICATION

In the world of refinishing, sprayers understand the balance of performance, quality and appearance. Spraying the next generation clearcoats from leading paint companies is no exception, demanding the ultimate performance from sprayers and their guns.

With the DV1 Clearcoat, DeVilbiss continues to build on the DV1 platform by introducing the latest edition of these next-generation spray guns.

The DV1 Clearcoat Spray Gun is designed specifically to provide consistency and optimization in spraying the range of industry-leading clearcoats. From high-solid clears, low-to-medium-solid clears or low VOC (solvent exempt) clears, the DV1 Clearcoat Spray Gun pushes atomization to the next level. Through faster performance, proven material savings and superior atomization, the DV1 Clearcoat Spray Gun gives sprayers the confidence to know that they can achieve a high-quality, perfect finish every time.

The solution to spraying clearcoats has never been so clear.



NEW ADDITION TO THE FAMILY

The DV1 Clearcoat Spray Gun is the latest addition to the DV1 family of revolutionary spray guns designed for specific applications.

Introduced in 2018, the DV1 Basecoat Spray Gun transformed the industry through its unique design and optimization of basecoat application. The DV1 Clearcoat leverages this DV1 platform and introduces modifications engineered specifically to optimize spraying the range of leading clearcoats on the market today.

Both the DV1 Basecoat and DV1 Clearcoat boast comprehensive features that revitalize the spraying process, including:

- **Silent-action trigger** designed to remove sideways and rotary play to deliver a soft, smooth pull
- **Quick release air cap** for quick and easy changes and easy access to the fluid tip
- **Integrated digital gauge** placed in-line at eye level for quick, easy checking while providing precise inlet pressures for optimal gun performance
- **Streamlined gun body** with an ultra-comfortable ergonomic fit and feel to provide sprayers balance, optimal control and less fatigue
- **Reconfigured air adjusting valve** placed in an ergonomic location for more comfort and 12 times the sensitivity for precise air control adjustments and smoother air flow
- **Simplified air valve** for maximized fluid needle alignment and durability, minimized component wear and easier removal and serviceability

**THE CONTROL
YOU WANT. THE
PERFORMANCE
YOU NEED.**



The DV1 Clearcoat features an innovative air and fluid management system optimized for superior clearcoat atomization. This gun provides a consistent, homogeneous spray pattern that lays the clearcoat flat for a flawless finish.

Sprayers can experience multiple benefits of the DV1 Clearcoat, including:

THE RIGHT ATOMIZATION FOR THE RIGHT APPLICATION

The DV1 Clearcoat produces an even distribution of fine, uniformly sized particles that easily wet up a surface and flawlessly hang on vertical panels. Sprayers will instantly see an improved Distinctness of Image (DOI) and an overall brilliance in the reflective, mirror-like clearcoat finish.

OPTIMAL PERFORMANCE - MORE POWER, MORE EFFICIENT

The DV1 Clearcoat introduces a step-change in atomization by optimizing the air velocity while maximizing fluid flow at the same time. This delivers higher application speeds at lower pressures, enhancing the overall productivity and efficiency of the gun.

EASY TO USE

Easy to set-up and easy to use — sprayers of all levels are able to move quickly and efficiently while replicating nearly any finish virtually effortlessly.

TRANSFER EFFICIENCY

Less is more with less waste (and less reworks). With the DV1, sprayers will use less material and save more time.

LESS NOISE

Less blast means less noise. Thanks to advancements in the DV1 design, the efficiencies in this spray gun translate to a quieter application experience from a soft-spraying gun, ultimately making it more enjoyable to use.

AIR STABILIZATION

Reduction of chaotic energy at the apex of atomization produces a more even, stable and consistent spray fan to produce the glass-like clearcoat finish sprayers know and love.

IMPROVED SPRAY PATTERN

The DV1 Clearcoat offers the most refined spray pattern yet. With tight, neat edges, flat sides and a flat bottom and top, the spray pattern optimizes the sprayer's efforts — minimizing the required overlap and number of passes a sprayer must make to lay the perfect finish.

MORE CONTROL

The DV1 Clearcoat provides sprayers the ability to produce a consistent overall finish across the whole work area — with minimal effort — while also experiencing a noticeable sense of more control of the spraying process.

ACHIEVE A FLAWLESS FINISH

THE DV1-C1 PLUS CLEARCOAT AIR CAP TECHNOLOGY

DeVilbiss is blazing a new trail in air cap technology with the DV1 family of spray guns. With the DV1 Clearcoat Spray Gun, DeVilbiss now introduces the next generation of atomization performance with the DV1-C1 PLUS Clearcoat Air Cap.

This groundbreaking air cap delivers superior high-efficiency performance spraying industry-leading clearcoats; including:

- High-solid clears
- Low-to-medium-solid clears
- Low VOC (solvent exempt) clears

The DV1-C1 PLUS Clearcoat Air Cap provides the right finish with the perfect film build to produce a fine, mirror finish every time.

INNOVATIVE FLUID TIP DESIGN

The DV1 Clearcoat features an all-new fluid tip designed specifically for clearcoat applications. This new tip design increases fluid flow through the gun, while optimizing air velocity at the tip, minimizing material usage and maximizing distribution throughout the entire spraying process.

With this specific fluid tip design, sprayers will experience the benefits of:

- Faster performance
- Significant material savings
- Superior atomization

A SLEEK LOOK

The DV1 Clearcoat features a new matte black finish. It marries comfort with style, providing a sleek look and a better grip for comfortable handling.



DV1 CLEARCOAT SPRAY GUN

SYSTEM COMPONENTS & ORDER NUMBERS

Part Listing

Image Reference	Part Number	Description	Quantity
1	-	Retaining Ring	1
2	-	Slip Ring	1
3	-	Retaining Ring Seal	1
4	704425	Retaining Ring Sub Assembly	1
5	-	Air Cap	1
6	191972	Spring Clip (Kit of 10)	1
7	See Table 1	Air Cap & Retaining Ring	1
8	See Table 2	Fluid Tip	1
9	704402	Deflector Plate	1
10+	704403	Screw (Kit of 3)	3
11	-	Sprayhead	1
12+	704401	Gasket (Kit of 2)	1
13	704436	Spray Head Kit	1
14	-	Needle Packing	1
15	-	Packing Spring	1
16	-	Packing Nut	1
17+	702731	Packing, Spring & Packing Nut Kit	1
18	-	O Ring	1
19	-	Air Valve Cage	1
20	-	Seal	2
21	-	Seal Guide	2
22	-	Valve Seat	1
23#	704422	Front Cage Assembly	1
24	-	Air Valve Stem	1
25#	-	Air Valve Spring	1
26	-	Rear Seal Housing	1
27	704423	Rear Seal Assembly	1
28+	704424	Air Valve Assembly	1
29	-	Identification Sleeve	1
30	-	Sleeve Nut	1
31	704437	Sleeve Kit	1
32	See Table 2	Fluid Needle	1
33	-	Needle Spring	1
34	-	Spring Pad	1
35#+	704405	Needle Spring Kit	1
36	704404	Fluid Adjusting Knob	1
37	-	O Ring	2
38	-	Flow Valve Body	1
39	-	Flow Valve Knob	1
40	-	Circlip	1
41	704417	Inline Flow Valve	1
42	-	Plug	1
43	-	Trigger Screw	1
44	-	Spring	1
45	-	Trigger Stud	1
46	-	Trigger	1
47	704406	Trigger, Stud, Spring & Screw Kit	1
48	-	Screw	1
49	-	Spreader Valve Pin	1
50	-	Spreader Valve Stem	1
51#+	-	O Ring	1
52	-	Valve Body	1
53#+	-	O Ring	1
54	-	Spreader Valve Adjusting Knob	1
55	704419	Spreader Valve Kit (Not for use with digital gauge)	1
56	704418	Spreader Valve Assembly	1
57	-	Valve Tool	1
58	-	Torx Driver	1
59	-	Tip Wrench	1
60	704429	Tool Kit	1
61*	GFC-501	Gravity Cup Plastic (Shown)	1
	702576	Gravity Cup Aluminum	1

Gauges

62	704426	ATEX Approved (EU)	Digital Pressure Gauge
	704427	FM Approved (USA, Canada)	

Service Kits

	704430	Minor Service Kit	Includes Items Marked #
	704431	Major Service Kit	Includes Items Marked +

*Cup not included in North America kit

Table 1: Performance Guide

Air Cap Part Number	704434
Air Cap & Type	DV1-C1 Plus (HVLP)
Recommended Air Pressure at Digital Gauge	1.5 bar (22 psi)
Air Consumption	285 L/min (10.0 scfm)
Fluid Flow	140 - 190 g/min
Pattern Height	325 mm (12.8 in)

Table 2: Tips & Needles

Fluid Tip			Needle	
Part Number	Size	Marking	Part Number	Marking
704440	1.0	DV1-1.0 C	704416	DV1-300
704441	1.1	DV1-1.1 C		
704442	1.2	DV1-1.2 C		
704443	1.3	DV1-1.3 C		
704444	1.4	DV1-1.4 C		

Spray Gun Kit

Order Number	Description	Air Cap	Gauged	Needle	Cup Type
704520	DV1 Clearcoat C1 Plus, Gauged	DV1-C1 Plus	DGI Pro Pod	1.2, 1.3, 1.4	Uncupped, Includes DPC Adapter

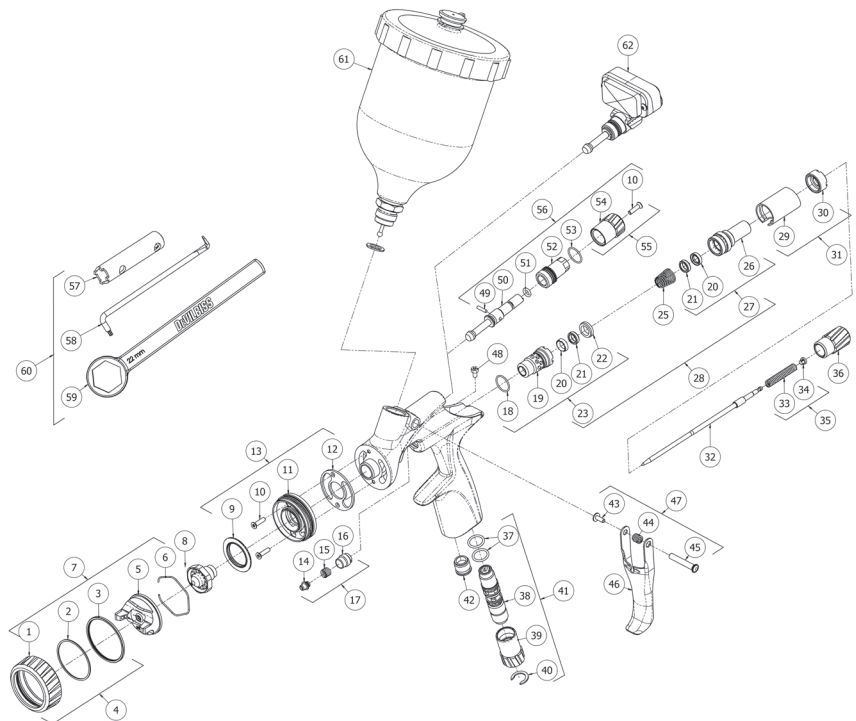

ABOUT CARLISLE FLUID TECHNOLOGIES AND DEVILBISS AUTOMOTIVE REFINISHING

Carlisle Fluid Technologies is a global solutions provider for the supply, control, application and curing of sprayed and dispensed materials including paints, coatings, powders, sealants and adhesives. It is best known for world-leading product brands *BGK*®, *Binks*®, *DeVilbiss*®, *ms*® and *Ransburg*®. To learn more visit **CarlisleFT.com**.

DeVilbiss Automotive Refinishing is a Carlisle Fluid Technologies brand featuring products designed to deliver premium finishes for the professional automotive repair shop. DeVilbiss brand products include low-pressure manual and automatic spray guns and related accessories, including air filter reducing valves and regulators, operator breathing systems and hoses.



DeVilbiss Automotive Refinishing

1-800-445-3988 | askus@carlisleleft.com | autorefinishdevilbiss.com

devilbissdv1.com



1-800-992-4657 | askcft@carlisleleft.com | carlisleleft.com

©2019 Carlisle Fluid Technologies, Inc.
BGK, *Binks*, *DeVilbiss*, *ms* and *Ransburg* are registered trademarks of Carlisle Fluid Technologies, Inc.
Models and specifications subject to change without notice. All rights reserved. | 19CFT468 | Form No. 09-007-01